



Procedures and Technical Standards for Electronic Citations Integration Program

I. Introduction

The Oregon Judicial Department (OJD) developed a custom integration for the Odyssey Case Management system allowing law enforcement agencies the option of electronically submitting citations (eCitations) to Oregon's Circuit Courts via the OJD Enterprise Technology Services Division (ETSD). These are the procedures and technical standards for local and state agencies that wish to participate in OJD's eCitation Integration Program.

II. Agency Requirements

Procedural

1. Review Procedures and Technical Standards for the Oregon Judicial Department's Electronic Citations Integration Program (eCitations) document.
2. Identify a vendor or in house technical team that will be responsible for implementing eCitations for your agency.
3. Complete the OJD's Law Enforcement Agency Application to Participate in eCitations and work with ETSD to receive eCitations Agency Approval.

Technical

1. Properly formatted court copy of the citation for presentation to the court.
 - The court copy of the citation must be produced using a PDF.
2. Conformance with OJD business rule.
 - Data collection and manipulation for purposes of the eCitation integration must be in conformance with the OJD business rules.
 - See [Section IV: Agency Applications Must Incorporate OJD Business Rule](#) for additional details on OJD Business rule.
3. Properly formatted citation date
 - eCitation schema, code tables, and Oregon Traffic Electronic Citation Message Definition will be distributed by ETSD.
 - OJD standard schema and code tables are used for purposes of developing data mapping. OJD schema and code tables are not modifiable.
 - Agencies monitor and update data mapping when there are changes to the OJD Code Table.
 - Agencies are responsible for reviewing rejected citations, determining why they were rejected, resubmitting the citation upon correction and training their staff to reduce future rejections.

Procedures and Technical Standards for Electronic Citations Program (eCitations)

2. Proper transmission of citation data and images to OJD's specified "FTPS" location.
3. Support
 - Identification of contact personnel: the agency (and any vendor utilized by the agency) must identify key personnel responsible for supporting the citation system, as well as tracking down issues that arise in the field.

III. High Level Overview

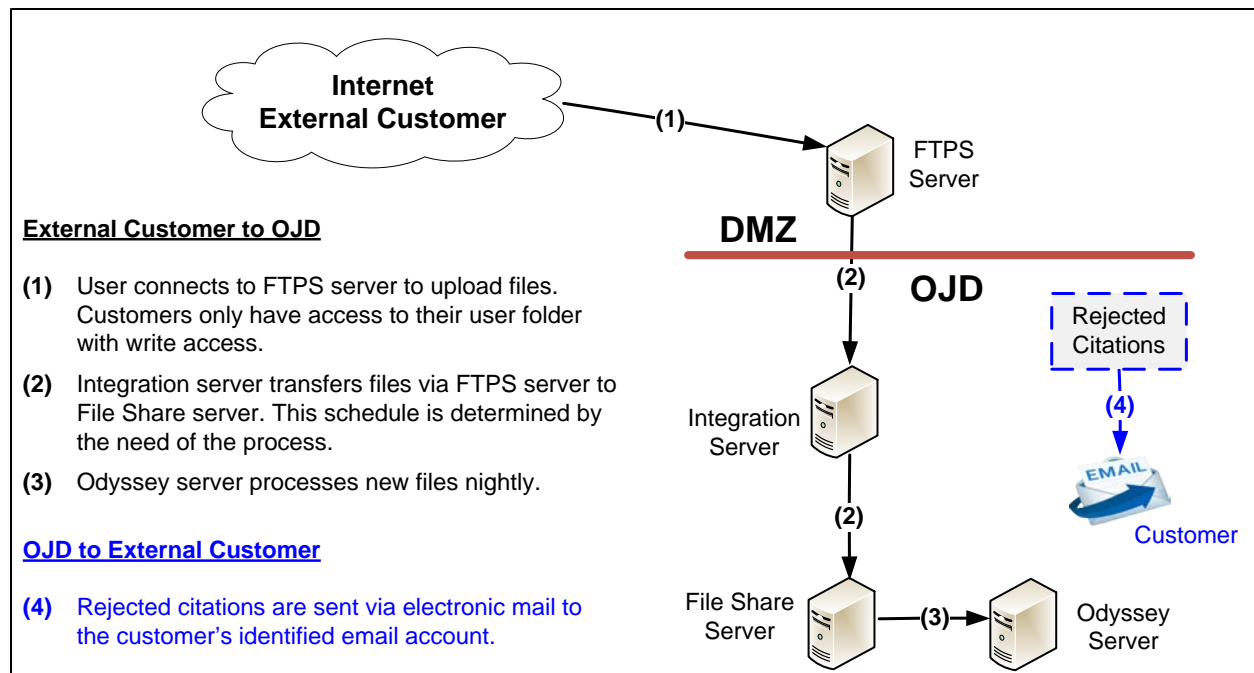

IV. OJD Transmission Requirements

The agency application must conform to the following:

1. XML submitted must be valid according to eCitation.XSD schema provided by ETSD.
2. Use FTPS credentials assigned to the agency by ETSD.
3. In order to electronically file the agency must submit a PDF version of the defendant's copy of the citation and an XML file that conforms to OJD schema.
4. Each citation must contain a unique citation number.

V. Security Requirements

The eCitation Integration Program consists of both law enforcement technology and OJD technology that work together to securely deliver citation information in digital form to Oregon's Circuit Courts. Major components consist of establishing secure network connectivity to agency partners and using FTPS as a transfer protocol.

VI. Statute and Code List Updates

eCitation utilizes Oregon Revised Statutes (ORS) and Odyssey code tables that are subject to occasional changes. Law enforcement agencies/vendors are required to use this information for purposes of mapping agency data to Odyssey case management system. When there are changes to the ORS and/or the Odyssey code tables, OJD will publish the updates and notify the law enforcement agency of the change. The participating agency is responsible for updating their application to reference the updated values to avoid rejected citations.

VII. Agency Applications Must Incorporate OJD Business Rule

Any application acting as a front-end for eCitations must conform to OJD business rules:

Required Fields (under all circumstances)

1. Citation Number
 2. Offense Date and Time
 3. Offense Number (ORS)
 4. Incident Location
 5. Traffic
 6. Violation
 7. Date and Time of Issuance
 8. Defendant's First Name¹
 9. Defendant's Last Name
 10. Badge Number
 11. Court Appearance Location (exact match Odyssey)
- } or 7. Business Name, or 8. Nickname

If speeding violation, include

1. Actual Speed
2. Posted Speed

If any driver's License information is provided all fields are required.

1. Driver's license number
2. State of Issuance
3. Last Name
4. First Name

If any address information is provided, all fields are required.

1. Address
2. City

¹ Names, Business Names and Nicknames are a selection but the default is First Name and Last Name.

3. State
4. Postal Code

OJD Specific Business Rules

1. OJD only accepts violations for appearance in a circuit court. Municipal and justice court citations should be filtered out and will be rejected if sent.
2. Only citations containing violations are accepted by OJD. All crimes must be filed with the District Attorney's office.
3. Warnings are not part of eCitations; officer must handle by paper.
4. Citation data must be accompanied by a pdf image of the citation as issued to the defendant.

VIII. Support Provided By the Agency

Inevitably, problems will arise in eCitations that cannot be trapped even by the best-designed automated systems. The schema validation process and the OJD business rules operate to minimize these situations. When a problem arises, it is essential that the agency have personnel in place who are familiar with their mobile and agency applications, and who know how to contact the officer who issued the citation to understand how the problem occurred. The agency (in conjunction with any involved vendor) needs to ensure ample officer training on the system involved.

As part of this support structure, ETSD provides a parallel test platform whereby an agency can issue a citation in TEST mode for testing purposes.